

uandksound LS-701B

Lawn Outdoor Loudspeakers

FEATURES:

- Water protected to IEC529 IP66.
- Lightweight ABS resin enclosure that is mechanically strong and resistant.
- UV protected for many years of outdoor installation.
- High quality coaxial 2 way speaker system.
- ABS unicasé technics.
- Matching transformer with multi tapings for 100/70V input.
- 360° omnibearing direction design for wide listening area.



Rated input:	30W
Impedance:	333, 666 ohm
Power Taps:	100V: 30W, 15W 70V: 15W, 7.5W
SPL (1W/1m):	92dB
MAX SPL (Rated/1m):	107dB@100/70V
Frequency Response (-10dB):	80Hz-20000Hz
Dispersion (4kHz/1kHz):	360°
Power Selecting Way:	Three Core Cable + Power Selection
Material:	High Impact ABS
Temperature/Humidity:	-30-60°C; <95%
Water Protection:	IEC529 IP66
Loudspeaker Component:	6.5" Woofer + 1" Coaxial Tweeter
Dimensions (mm):	325 W x 325 D x 335 H
Weight unit:	3.5 kg
Mounting:	4 x 9mm Screw Hole Mounting

Earth

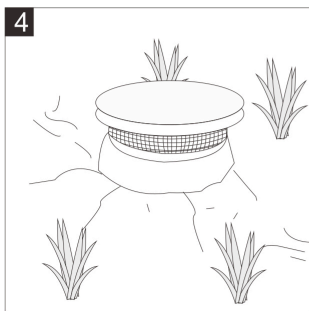
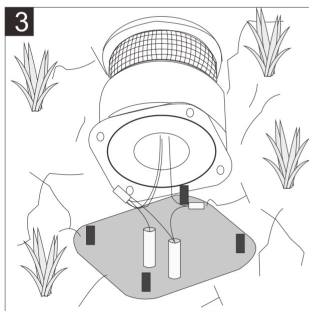
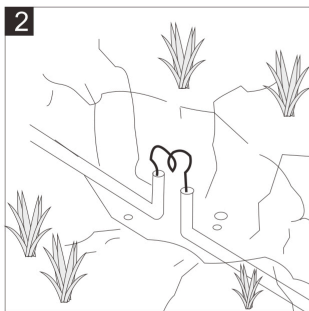
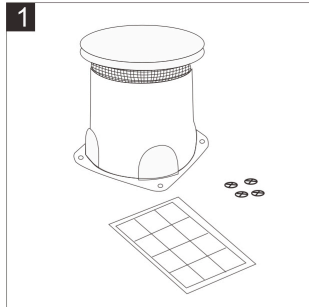

Concrete or wood

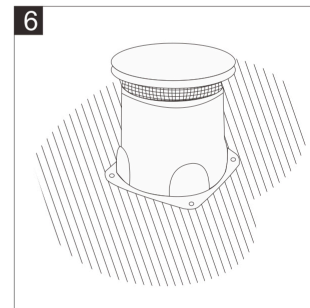
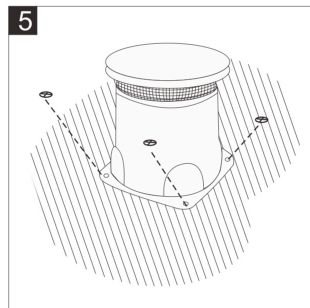
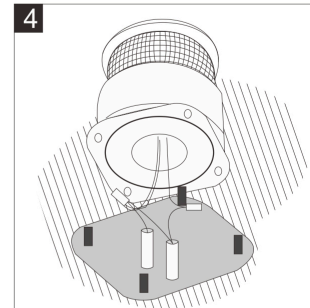
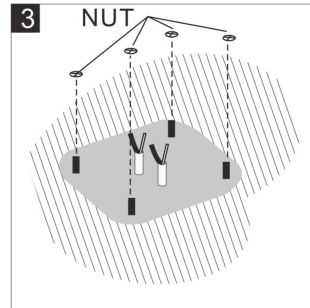
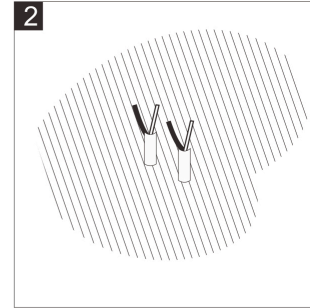
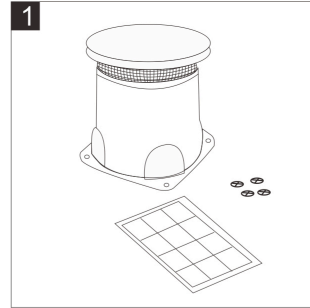

Power switch (only for LS-701B)

